

Z08/...

Mat.: 1.2343/53 ± 1 HRC

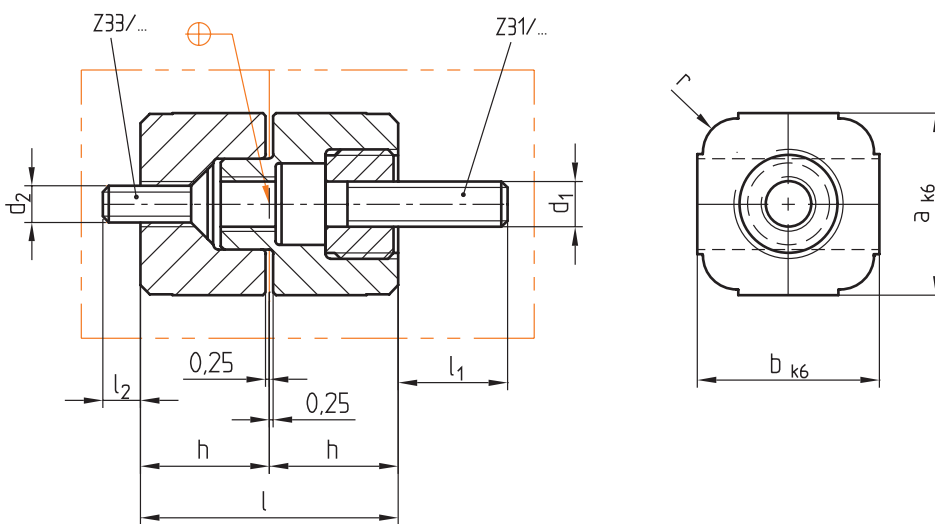
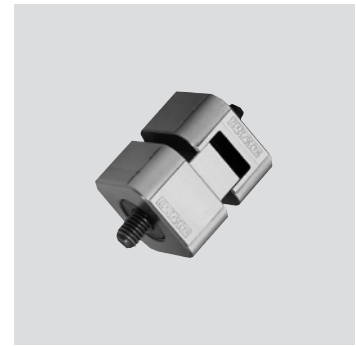

r	d ₁	d ₂	l ₁	l ₂	l	h	a	b	Nr./No.
4	M 5	M4	12	4	28	14	20	20	Z08/20x20
5	M 6	M5	13	8	32	16	25	25	25x25
6	M 8	M6	15	12	36	18	32	32	32x32
	M10	M8	17	10	45	22.5	40	40	40x40

This is trial version
www.adultpdf.com